



NZ DESIGN GUIDE

NAILPLATES

2024

PRYDA BUILDING GUIDE OVERVIEW

Pryda has developed this guide to accommodate New Zealand building practices. It is important that designers, engineers, builders, inspectors and building authorities are familiar with the benefits and critical requirements of the system. Pryda timber connectors, trusses and beams comply with the New Zealand Building Code, Section B1 Structure and B2 Durability, having been designed in accordance with sound and widely accepted engineering principles to comply with NZS3604:2011.

The capacities reported in this publication are limit state design capacities and not characteristic strengths thereby allowing direct comparison with design reactions reported in Pryda design software and Pryda design reports. This document supersedes and replaces all the previous publications of Builder's Guide.

For further design advice or engineering support regarding the Pryda products discussed in this publication please phone us at **0800 88 22 44** or visit our website - **www.pryda.co.nz**.

The Pryda Design Guide features a Building Consent Documentation Reference for many connection details. This is aimed to encourage designers to align details in the building consent documentation with useful information for easy reference for builders and building officials at the time of inspection. The process is illustrated on the following page. It should be recognised that this is not a requirement, and fabricators may choose to present information in various formats.

The **Building Consent Documentation Reference** should not be confused with the Pryda product code.

The Company

Pryda New Zealand is an autonomous division of USA-based Illinois Tool Works Inc. a Fortune 200 diversified manufacturing company with almost 100 years of history. Other successful ITW brands include Paslode, ITW Proline, Ramset and Reid Construction Systems. Pryda also gains valuable benefits in product, fabrication machinery and software development from its association with other ITW software and truss connector suppliers from around the world.

Who is Pryda?

Pryda was born in Napier, New Zealand in 1964. Pryda has remained an integral part of the building industry in New Zealand for over 50 years, particularly in timber truss and

frame solutions with the development of a diverse range of timber connectors and structural brackets. Today Pryda remains a trusted New Zealand brand on building sites, in trade stores and in offices of architects, engineers and designers.

Pryda utilises world-class technology to provide a total system package to its licensed truss and frame plants, including fully integrated software and production systems, access to world leading manufacturing equipment and the highest levels of technical support.

Our Philosophy

Pryda develops solutions to common construction challenges on the philosophy, "**safer, faster, smarter, easier**".

Pryda's philosophy is a unique method of looking at the total business needs of its licensed truss and frame fabricators and providing cost effective solutions that not only meet current requirements but also identify and satisfy long term goals.

BUILDING CONSENT DOCUMENTATION REFERENCE INDEX

| | | | |
|--------------------------|------------------------------------|---|---|
| FOUNDATION & SUBFLOOR | Subfloor Fixing | P6 | 6kN Pile Bearer Kit |
| | | P12 | 12kN Pile Bearer Kit |
| | Foundation Strengthening | LB1 | 10kN Load Foundation slab strengthening |
| | | LB2 | 20kN Load Foundation slab strengthening |
| LB3 | | 30kN Load Foundation slab strengthening | |
| WALL | Bottom Plate Fixing | BP1 | Sheet Brace Strap 6kN |
| | | BP2 | Sheet Brace Strap 12kN |
| | | BP3 | Stud Anchor 6kN |
| | | BP4 | Stud Anchor 12kN |
| | | BP6 | Bottom Plate Anchor |
| | Timber Lintel Fixing system | L1 | 1.4kN lintel fixing |
| | | L2 | 2.8kN lintel fixing |
| | | L3 | 8.0kN lintel fixing |
| | | L4 | 14.0kN lintel fixing |
| | Top Plate to Stud Connection | TPO | 0.7kN Top Plate to Stud |
| | | TP1 | 1.7kN Top Plate to Stud |
| | | TP2 | 2.5kN Top Plate to Stud |
| | | TP3 | 4.7kN Top plate to Stud |
| | Claw Beam Connection System | L9 | Claw Beam Lintel Fixing Various |
| | | L10 | Claw Beam Lintel Fixing Various |
| L11 | | Claw Beam Lintel Fixing Various | |
| L12 | | Claw Beam Lintel Fixing Various | |
| L13 | | Claw Beam Lintel Fixing Various | |
| L14 | | Claw Beam Lintel Fixing Various | |
| ROOF FRAMING | Roof Component Tie Down Connection | Z | 2 / Z nails ZL or ZR |
| | | U | 2 / U nails |
| | | CP9 | 2 / CPH190 Ceiling Purlin /Hanger |
| | | X | 1 / MGL (Multigrip long) |
| | | 2X | 2 / MGL |
| | | NC4 | 1 / NPPC4 Concealed Purlin Cleat |
| | | NC6 | 1 / NPPC6 Concealed Purlin Cleat |

| | | | |
|---------------------|---|-------------------|--|
| ROOF FRAMING | Roof Component Tie Down Connection | NC8 | 1 / NPPC8 Concealed Purlin Cleat |
| | | Q6 | 1 / MPQHS6 Cyclone Strap |
| | | Q9 | 1 / QHS9 Cyclone Strap |
| | | Q6* | 1 / MPQHS6 Cyclone Strap, wrap legs under support member |
| | | Q9* | 1 / QHS9 Cyclone Strap, wrap legs under support member |
| | Roof Component to Roof Component Connection | VS | Variable Skew Hanger |
| | | MG | Multigrip |
| | | MGL | Multigrip Long |
| | | A | MPFB4590 Joist Hanger |
| | | B | MPFB45120 Joist Hanger |
| | | C | MPFB45180 Joist Hanger |
| | | D | FB94/152 Joist Hanger |
| | | NC8 | 2 / NPPC8 |
| | NPA | 2 / Nail-on Angle | |

BUILDING CONSENT DOCUMENTATION REFERENCE

The Pryda Builders Guide features **building consent documentation references** for many connection details. This is aimed to encourage designers to align details in the building consent documentation with useful information in the Pryda Builders Guide for easy reference for builders and building officials at the time of inspection. The process is illustrated below.

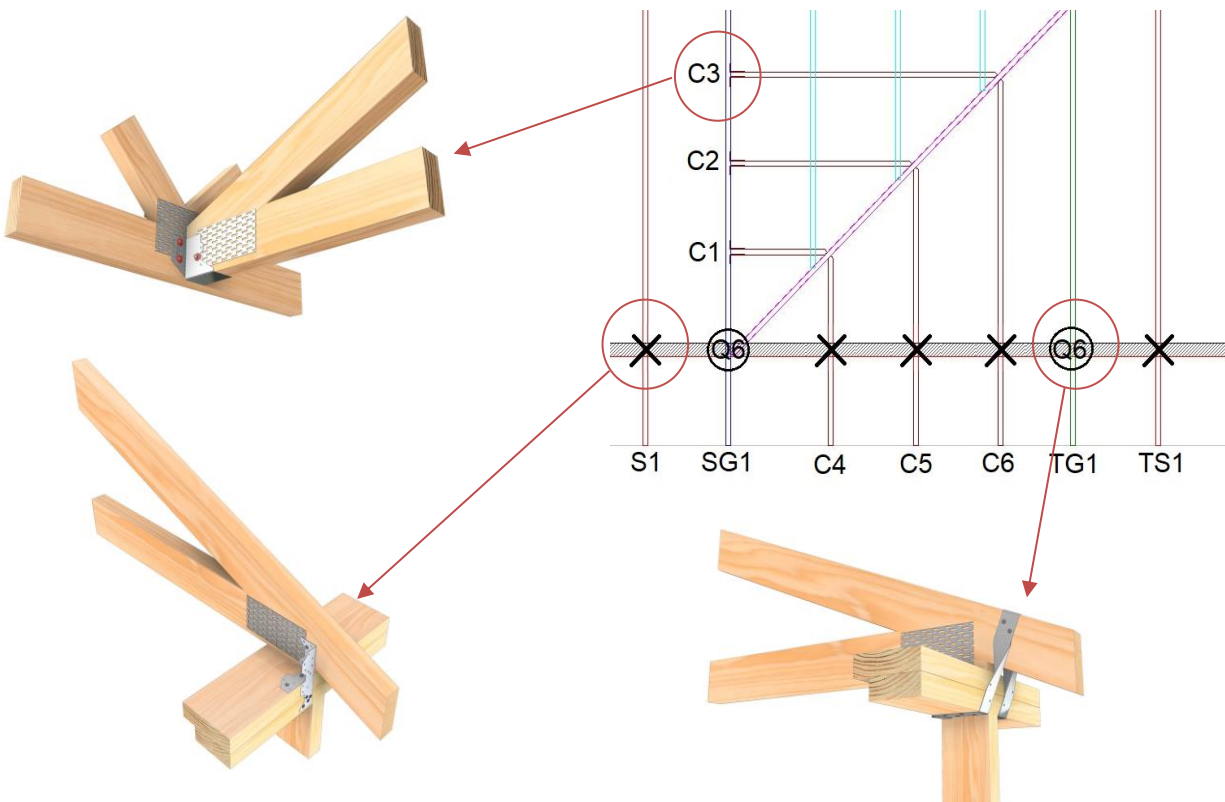

FRAME & TRUSS MANUFACTURERS ASSOCIATION CODE OF PRACTICE

1 The Code of Practice

1.1 Purpose

The FTMA Code of Practice is intended to provide a means of assurance to consumers, specifiers, and Building Consent Authorities (BCAs) by way of publishing the standards and procedures that members agree to. In this way there is a basis for comparison with non-members as well as an industry-based benchmark from which expectations can be managed.

1.2 Intention

It is intended that:

- Adherence to the Code of Practice will enable a qualifying fabricator to certify and mark their product as compliant to the Code of Practice.
- After a period of implementation and review adherence to the Code of Practice will be audited by a third-party auditor.
- That adherence to the Code of Practice will be required for membership of FTMA.

1.3 Content

The Code of Practice includes:

- Section 2 - Truss Documentation

2 Truss documentation

2.1 Introduction

The intention of this section is to describe the documentation required to be produced by a fabricator of nail-plated timber trusses for use by its customer. The information contained in the document may be used by a Building Consent Authority (BCA) to satisfy the provisions of the Building Act 2004 and reasonable BCA processes in the issuing of a Building Consent or Code Compliance Certificate (CCC).

For practical purposes, the production of the documentation is a two-stage process. The first stage is to provide documentation to support the issuing of a building consent.

This can be achieved by providing:

- a 'Buildable' truss layout.
- Fabricator Design Statement.
- a Producer Statement – Design.

These documents show that trusses have been designed by an accredited fabricator¹, licensed to use specific design software, applying the appropriate loads, and using the appropriate materials to ensure compliance with the NZ Building Code (NZBC) as well as giving notification of any resultant loads that may affect the supporting structure.

This documentation is intended to be provided to the “design lead”² to then consider when completing the structural design before providing it to the BCA as part of a building consent application. The BCA may then issue a building consent that is subject to receiving further documentation. The second stage is to support the issuing of the CCC and is required prior to on-site inspection by the BCA.

This can be achieved by providing:

- an 'As Built' truss layout.
- a Fabricator Design Statement.
- a Producer Statement – Design.
- a Manufacturing Statement.

This is similar documentation to that provided for the first stage but ensures that the final construction details of the manufactured trusses accurately reflect what was built, which can then be recorded by the BCA as part of the project documentation. Such further documentation then satisfies the conditions on which the consent had been issued. The documentation is intended to be provided to the builder on-site and to the customer who should make it available to the BCA prior to on-site inspection.

When producing an 'As Built' truss layout and final truss detailing for supply, it is expected that a fabricator shall give consideration to any 'Buildable' truss layout that has been consented by a BCA. The fabricator shall consider any structural implications that may result from a different layout to that consented and if any changes are to be made then these shall be communicated to the customer to pass on to their design team for consideration and approval before proceeding with supply. It is not expected that fabricators should have to follow exactly a consented layout, particularly when a competitive party may have provided it. However, a fabricator will have to produce an 'As Built' truss layout as per 2.3.1. This two stage process is reflected in section 7.5 of the guidance document "Guide to applying for a building consent" published by the Department of Building and Housing. Acknowledgement and support for the COP Section 2 – Truss Documentation is also outlined in the publication from DBH Codewords issue 044. Both publications are available online at www.dbh.govt.nz.

While it is expected that the documentation is going to be provided to assist a BCA in the consent or CCC process it should be noted that the contractual relationship is between a fabricator and its customer and that the responsibility to provide this information to a BCA rests with the applicant for a building consent.

Notes:

1. An accredited fabricator is a company that has a formal agreement with a nail-plate manufacturer to use their products in the manufacture of trusses. The nail-plate manufacturer in turn licenses the fabricator to use specific design software supplied and underwritten by the nail-plate manufacturer.
2. A design lead refers to the architect or draftsman responsible for the overall design of the building.

PRODUCER STATEMENT PRYDA TIMBER CONNECTORS

August 2024

This Producer Statement is issued by Pryda NZ to cover the use, installation, and durability of Pryda Timber Connectors for both structural application and durability as required by the New Zealand Building Code clauses B1 & B2, respectively.

Description

The Pryda timber connectors are manufactured from either Z275 or Z600 galvanised coil. Some brackets are also available in hot dipped galvanised or stainless steel for use in certain exposed and covered situations.

Application

Pryda timber connectors are designed for specific connections of timber to timber, primarily, as well as masonry, concrete, and steel. Please contact Pryda should you require assistance relating to these connectors.

Installation

Pryda timber connectors should be installed without damage to the finished surfaces. Storage prior to use to be in dry moisture free conditions that would not affect the future durability of the product.

Design Capacity

As timber grades vary the design capacity is derived using the methods in NZS AS1720.2022 and is mostly dependent on the shear values of the nails, screws, and bolts in timber. Most commonly used Timber Connectors have published limit state design strengths published in our literature.

Durability

The durability of Pryda timber connectors is in accordance with the acceptable solutions contained in Table 4.1 and Table 4.2 of NZS3604:2011 to achieve a 50 year life expectancy for the connectors where applicable. Alternative solutions and direct applications are to be found elsewhere in this publication.



Dr. Kristopher Orlowski
BSc (Eng), MEng, DR-PHILENG, CPEng AUS (4125476), CPEng NZ (2001879)

STRUCUTRAL ENGINEER

Pryda

ITW Construction, Asia Pacific

41 Poland Rd, Glenfield, 0629
PO Box 100303, North Shore 0757, Auckland.

Tel: 0800 88 22 44

Email: info@prydaanz.com

PRODUCER STATEMENT STRUCTURAL BRACKETS

Pryda Structural Brackets

August 2024

This Producer Statement is issued by Pryda NZ to cover the use, installation, and durability of Pryda Structural Brackets for both structural application and durability as required by the New Zealand Building Code clauses B1 & B2, respectively.

Description

Pryda Structural Brackets are fabricated from flat bar steel. They are mostly available in hot dipped galvanised finish with a selection also available in stainless steel for use as an architectural feature or in certain exposed and covered situations as covered in NZS3604:2011. The zinc coating is applied in accordance with AS/NZS 4680:2006. The remaining Pryda Structural Brackets are finished in electro galvanised.

Application

Pryda Structural Brackets are designed to connect timber to masonry, concrete, and steel. The brackets are designed for specific connections of timber to other materials. Please contact Pryda technical service should you require assistance with your intended application.

Installation

The Pryda Structural Brackets should be installed without damage to the finished surfaces. Storage prior to use to be in dry moisture free conditions that would not affect the durability of the product.

Characteristic Strength

When used with timber, the characteristic strength is derived by the verification method in accordance with the NZBC standard NZS3603:1993. The withdrawal strength of the bracket varies with the type of substrate it is installed in, hence the limit state design capacities shall be determined by the design engineer taking into consideration the above point.

Durability

The durability of the Pryda Structural Brackets is more than the acceptable solutions contained in Table 4.1 of NZS3604:2011 in order to achieve a 50-year life expectancy for the brackets. Pryda Structural Brackets are hot-dipped galvanised to a level equal to or exceeding 500g/m². Depending on the environmental conditions and exposure to marine conditions, the surface of the stainless-steel brackets can be affected by tea staining. However, tea staining does not affect the structural integrity of the fitting.



Dr. Kristopher Orlowski
BSc (Eng), MEng, DR-PHILENG, CPEng AUS (4125476), CPEng NZ (2001879)

STRUCTURAL ENGINEER

Pryda

ITW Construction, Asia Pacific

Pryda New Zealand

A division of ITW New Zealand Ltd 41 Poland Rd, Glenfield, 0629

PO Box 100303, North Shore 0757 Auckland

Tel: 0800 88 22 44

Email: info@prydaanz.com

ENVIRONMENT DEFINITIONS & PRODUCT SELECTION

Alternative solution to Table 4.1 NZS3604:2011

Under the building code, **Clauses B2 Durability**, requirements for steel fasteners are:

- For structural steel fasteners with difficult access and replacement - 50 years or nominated period
- For structural steel fasteners with moderate ease of access and replacement - 15 years or nominated period

Environment Definitions

Exposed/Sheltered

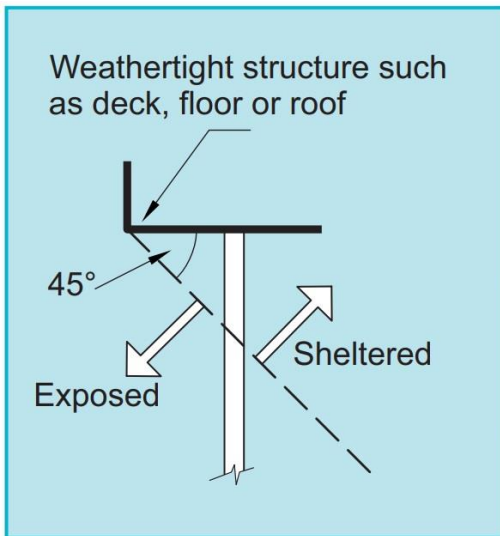

Closed

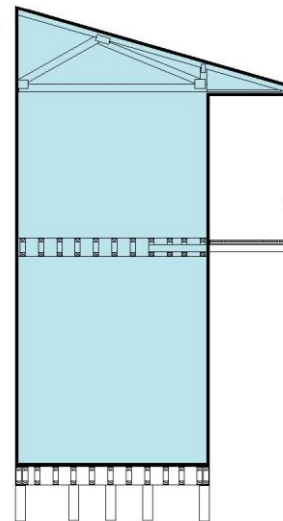

| Zone | Location | | Environment | Product |
|-------------|--|--|-------------|--------------------------------|
| All Zones | Fully enclosed walls, floors & roof spaces | | Closed | Pryda Zinc Coated Products |
| Zones B & C | All subfloor fastenings more than 600mm above the ground | Vented 7000mm ² /m ² or LESS | Sheltered | Pryda Stainless Steel Products |
| | | Vented MORE than 7000mm ² /m ² | Exposed | Pryda Stainless Steel Products |
| | All subfloor fastenings within 600mm of the ground | Sheltered and exposed | | Pryda Stainless Steel Products |
| | All other structural fixings | Sheltered | | Pryda Stainless Steel Products |
| Exposed | | Pryda Stainless Steel Products Pryda SBK HDG Brackets | | |
| Zones D | All structural fittings | Sheltered and exposed | | Pryda Stainless Steel Products |

Notes: All Pryda galvanised products comply with NZS3604:2011 Table 4.2

EXPOSURE ZONES



©Copyright Standards New Zealand 2011. Figure 4.2 from NZS 3604:2011 has been reproduced with permission from Standards New Zealand under Copyright License 000925.

NOTE - The sea spray zone includes all offshore islands, the area within 500 m of the coastline of New Zealand, and those areas shown in white. The map shall be read in conjunction with clause 4.2.2 of NZS 3604:2011.

Exposure zones

- Zone B
- Zone C
- Zone D

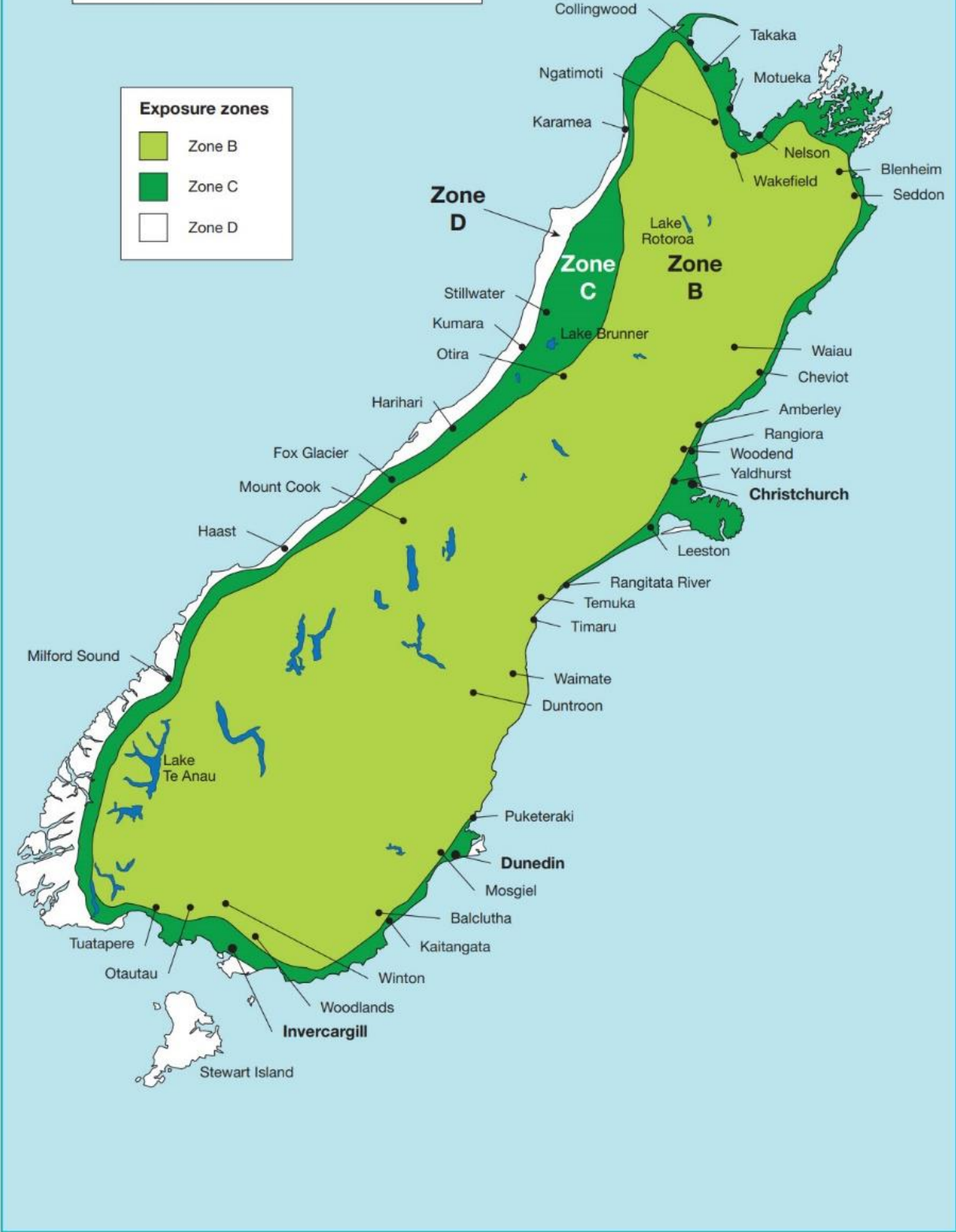

©Copyright Standards New Zealand 2011. Figure 4.2 from NZS 3604:2011 has been reproduced with permission from Standards New Zealand under Copyright License 000925.

EXPOSURE DEFINITIONS

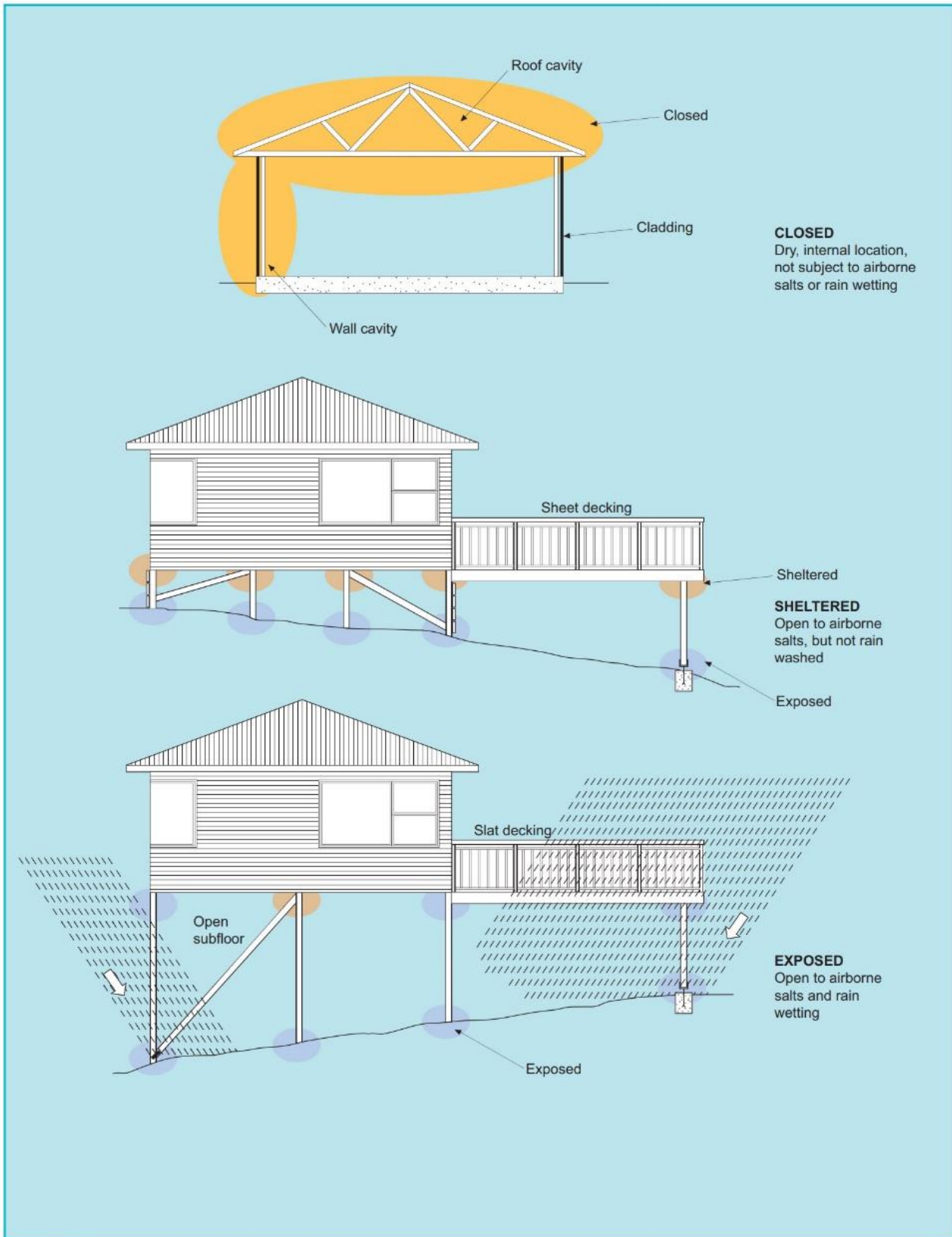

©Copyright Standards New Zealand 2011. Content from NZS 3604:2011 Timber-framed buildings has been reproduced with permission from Standards New Zealand under Copyright License 000925. Refer to the full Standard for full details available for purchase from Standards New Zealand at www.standards.co.nz
©Copyright Standards New Zealand 2011. Figure 4.3(b) from NZS 3604:2011 has been reproduced with permission from Standards New Zealand under Copyright License 000925.

NZ KNUCKLE NAILPLATE

Hammer fixed and easy to use connector for multiple applications.

CodeMark 
CMNZ-10031

FEATURES AND BENEFITS

SIMPLE: Can be installed without any special gear or nails, only a hammer is required for install

FAST: Hammer the knuckles and you are done. Multiple applications from timber jointing, splicing, reinforcement, and impact resistance.

DURABLE: 1mm thick, Z275 galvanised steel.

SPECIFICATIONS

| | |
|-----------------------------|--------------------------------|
| PRODUCT CODE | *See Knuckle plate range |
| STEEL | G300 |
| THICKNESS | 1.0mm |
| CORROSION RESISTANCE | Z275 |
| FASTENERS REQUIRED | Nil. Pre-punched knuckle nails |
| LENGTHS | 63mm - 254mm |
| WIDTHS | 33mm - 134mm |

At the time of print, this product is NOT subject to any known warnings and bans found in Building Act 2004.

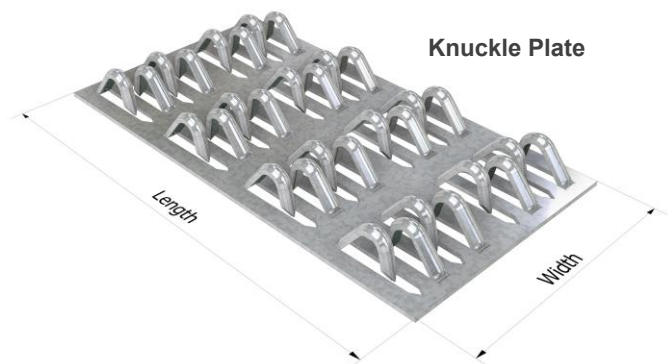
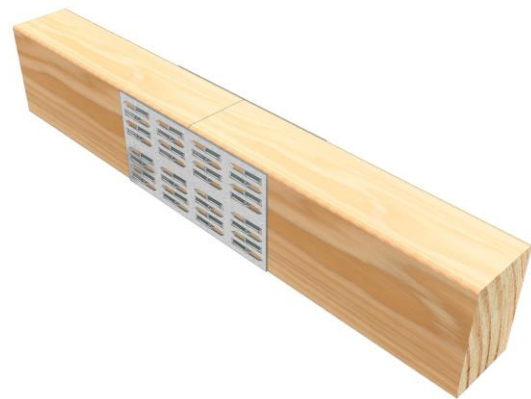

DESCRIPTION

Knuckle Nailplates are available in a wide standard range as tabulated.

The steel used is **1.0 mm thick, ZincForm® G300 Z275** or equivalent. Product codes for non-special plates refer to the number of columns of nails and the number of rows. E.g., a mp2r16 has 2 rows and 16 columns.

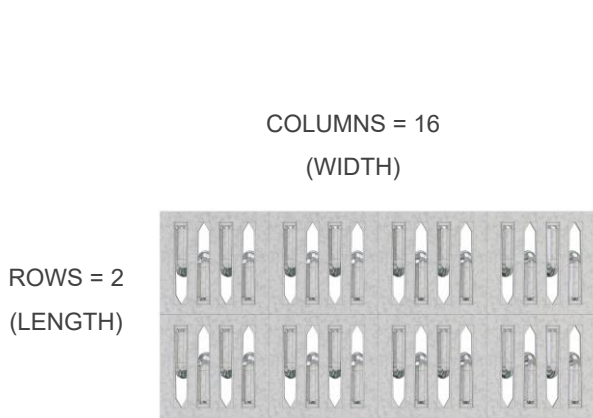

MP2R16 KNUCKLE PLATE
(63mm Length X 134mm Width)

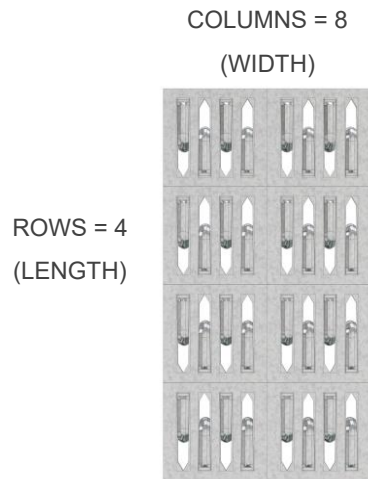

MP4R8 KNUCKLE PLATE
(127mm Length X 67mm Width)

KNUCKLE NAILPLATES

| PRODUCT CODE | MATERIAL | LENGTH | WIDTH | QUANTITY |
|--------------|----------------------------------|--------|-------|----------|
| MP2R4 | 1.0mm G300 Z275 Galvanised Steel | 63 | 33 | 200 |
| MP2R5 | | 63 | 38 | 200 |
| MP4R5 | | 127 | 38 | 100 |
| MP6R5 | | 190 | 38 | 66 |
| MP8R5 | | 254 | 38 | 50 |
| MP4R10 | | 127 | 76 | 50 |
| MP6R10 | | 190 | 76 | 33 |
| MP8R10 | | 254 | 76 | 26 |
| MP10R10 | | 317 | 76 | 20 |
| MP4R16 | | 127 | 134 | 33 |
| MP6R16 | | 190 | 134 | 22 |

KNUCKLE NAILPLATE KEY FEATURES

Pryda Knuckle Nailplates are galvanised steel connectors with in-built, bent up “knuckle” nails. These plates are ideal for many structural and non-structural timber jointing and timber protection uses. Applied simply by hammering in the “knuckle nails,” these plates are used by tradespeople, homeowners, frame and box manufactures, electricity supply authorities and builders. Special pressing equipment is not necessary.

Among the many uses of **Knuckle Nailplates** (see Applications following), the most common are:

- Jointing of wall frames together on-site.
- On-site splicing of timber beams.

Generally, **Knuckle Nailplates**:

- Provide a strong, economical, and easy-to-use means of jointing timber together.
- Protect timber from damage as they:
 - Resist splitting due to drying of the timber, nailing near ends or other causes.
 - Dissipate electricity current surges in cross arms over a larger area (e.g., Shunt plates).
- Distribute concentrated loads over a wider area, e.g., they increase the strength of bolted joints.
- Hold joints together, preventing or restricting the separation of nailed joints such as in boxes and crates.

PROPERTIES

Design Capacities for **Pryda Knuckle Nailplates** have been established from standard laboratory tests in accordance with AS 1649-2001 Timber – Methods of test for mechanical fasteners and connectors – Basic working loads and characteristic strengths. Loads are related to the standard joint groups for timber defined in AS/NZS 1720.

INSTALLATION

Knuckle Nailplates are installed simply by hammering on the knuckles of all nails in each plate. It is recommended that the hammer be parallel to the length of the nails (see diagram below) to ensure full penetration of the nails.

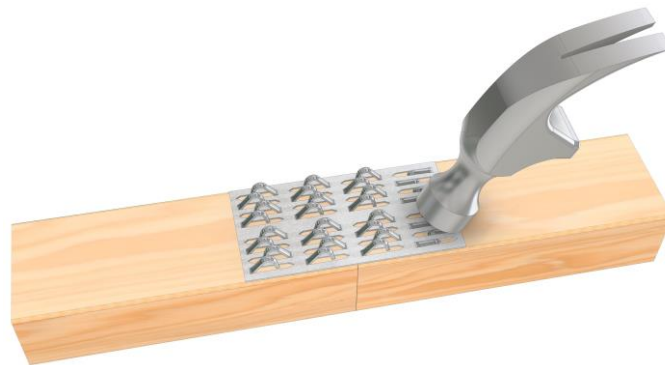

Hammer Parallel to Nails

A natural arc or dovetail effect is created by the nails as they penetrate the timber. This provides positive resistance to nail withdrawal.

For butt jointing, **Knuckle Nailplates** are installed symmetrically over the joint, i.e., with an equal length on each side (3 mm tolerance). For timber up to 150 mm wide, one plate is fixed onto each face; for wider timber, two plates are used, fixed at 3 mm maximum from each edge. Surface plane must be level for flat plate installation and no gaps between butt joints.

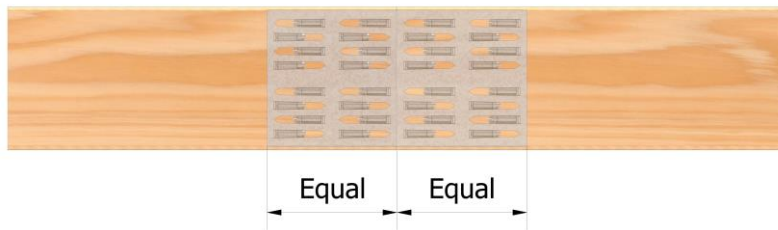
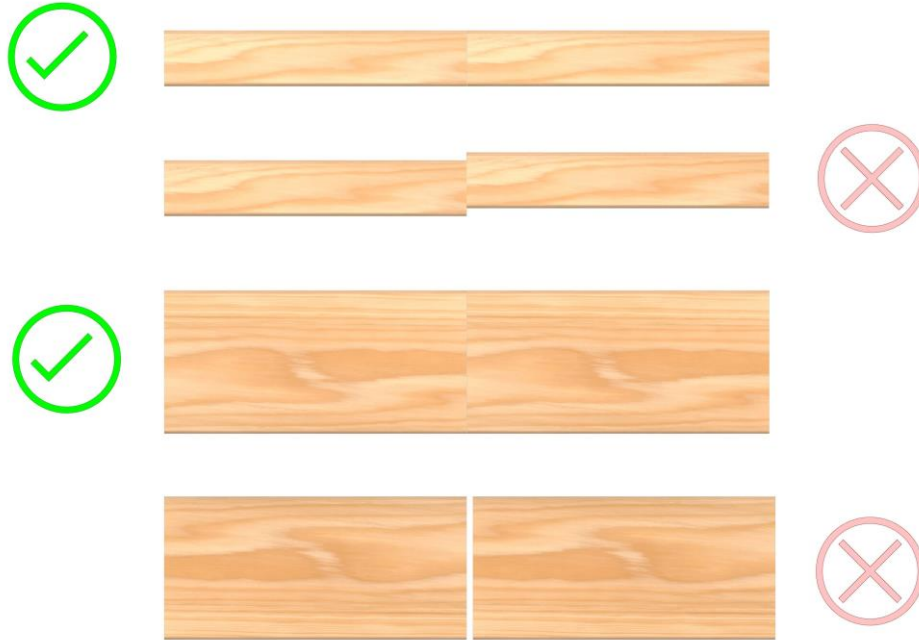

Single Plate Butt Jointing

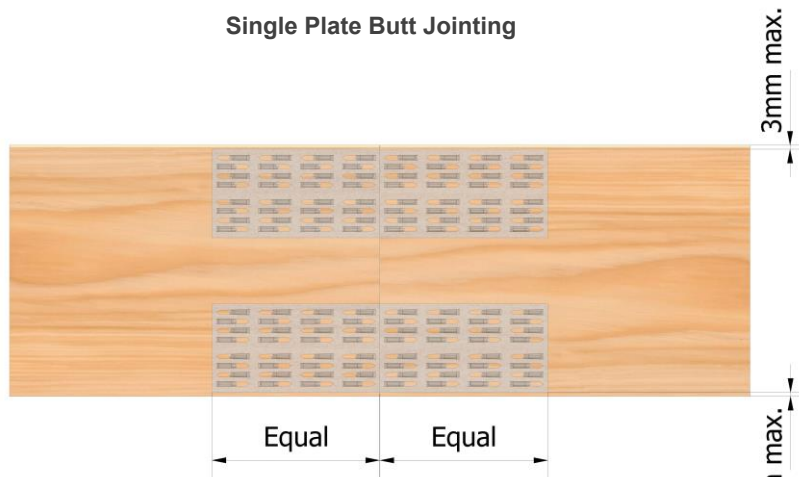

Double Plate Butt Jointing

DURABILITY

The following table provides an easy guide when selecting a Pryda product corrosion protection finish that will meet and exceeds NZS 3604:2011 table 4.1.

Pryda Knuckle Nailplates are only available in Z275, therefore suitable for “Closed” environment.

| ZONE | LOCATION | | ENVIRONMENT | PRODUCT |
|---------------|--|--|-------------|---|
| All Zones | Fully enclosed walls, floors, and roof spaces | | Closed | Pryda Zinc Coated Products Z275 |
| Zones B and C | All subfloor fastenings more than 600mm above the ground | Vented 7000mm ² /m ² or LESS | Sheltered | Pryda Stainless Steel 304 Products ⁽³⁾ |
| | | Vented MORE than 7000mm ² /m ² | Exposed | Pryda Stainless Steel 304 Products ⁽³⁾ |
| | All subfloor fastenings within 600mm of the ground | Sheltered and Exposed | | Pryda Stainless Steel 304 Products ⁽³⁾ |
| | All other structural fixings | Sheltered | | Pryda Stainless Steel 304 Products ⁽³⁾ |
| Exposed | | Pryda Stainless Steel 304 Products ⁽³⁾ | | |
| Zone D | All structural fixings | Sheltered and Exposed | | Pryda Stainless Steel 304 Products ⁽³⁾ |

Notes:

1.All Pryda galvanised products comply with NZS3604:2011 Table 4.2.

2.Refer to NZS3604:2011 for all environment definitions.

3.Routine inspection and cleaning using soap and fresh warm water is an integral part of the ongoing care and maintenance of stainless steel to preserve its appearance.

STORAGE AND HANDLING

Prior to use, the Pryda products shall be stored in a weatherproof environment and protected from moisture. Care must be taken to avoid any damage to the surface of the product protective galvanised coating and profile that may impact the performance.

COMPLIES WITH THE FOLLOWING PROVISIONS OF THE NEW ZEALAND BUILDING CODE (NZBC)

Clause B1 STRUCTURE: Performance B1.3.1, B1.3.2 and B1.3.4. Loads arising from self-weight, imposed gravity loads arising from use, earthquake, snow, and wind. (i.e., B1.3.3 (a), (b), (f), (g), and (h)). Only some may apply for a specific use of the component.

Clause B2 DURABILITY: Performance B2.3.1 (a) not less than 50 years and B2.3.2.

Clause F2 HAZARDOUS BUILDING MATERIALS: Performance F2.3.1.

APPLICATION AND SCOPE OF USE

Pryda Knuckle Nailplates are certified when used and installed in accordance with the product datasheet shown connection details. Pryda fasteners approved for the installation form an integral part of the connection and therefore should be used with all Pryda products installation unless otherwise approved by a certified structural Engineer. Only use the product for its intended applications and the selected product material type within the specified environmental condition as outlined in NZS 3604:2011 Table 4.1. (Refer to Durability section for more details).

Some of the many applications of **Knuckle Nailplates** are illustrated below:



Joining Top Pates



Purlin or Joist Splices



End Jointing

KNUCKLE NAILPLATE COILS

Knuckle Nailplate Coils are ideal for on-site users to cut Knuckle Nailplate to the required length by using metal cutters. Properties and features are similar to the Knuckle Nailplates.

| PRODUCT CODE | MATERIAL | LENGTH (m) | WIDTH (mm) | QUANTITY |
|--------------|----------------------------------|------------|------------|----------|
| NCR10 | 1.0mm G300 Z275 Galvanised Steel | 12.7 | 76 | 1 |
| NCR16 | | 8.45 | 134 | 1 |

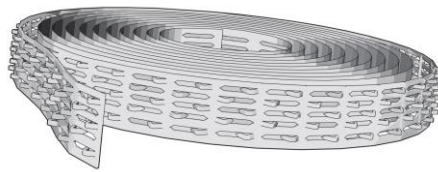

DESIGN CAPACITIES

Limit State Design capacities per single **Pryda Knuckle Nail** shown in table. Knuckle plate should be oriented with the plate knuckle slots direction with load direction.

| LOAD DIRECTION | LOAD CASE | DESIGN DEAD LOAD CAPACITY ϕ NJ (N) PER NAIL FOR TIMBER JOINT GROUP: | |
|----------------|--------------------------|--|--|
| | | Dry Timber | |
| Parallel | 1.35G | JD5 | |
| | 1.2G + 1.5Qf | 123 | |
| | 1.2G + 1.5Qr | 149 | |
| | 1.2G + Wd or Wind Uplift | 166 | |
| | | 247 | |

Notes:

1. *Parallel* in the above table applies to the case where the load is applied parallel to the nail slots in the plate and parallel to the timber grain (see diagram below). *Perpendicular* applies where the load direction is not as defined for *Parallel*.



Load direction
Parallel to nails slots
and parallel to timber
grain

2. The above capacities are given in Newtons for a single knuckle nail, adopting a capacity factor (ϕ) of 0.85 and load duration factor (k_1) of 0.6, applicable to permanent loads.

3. To calculate the number of teeth per plate, multiply the first figure in the plate code by the second :

- for 4R8, teeth = $4 \times 8 = 32$
- for 8R16, teeth = $8 \times 16 = 128$

On an area basis, there are conservatively, 3.5 nails per 1000 mm² of plate area.

In timber joint design, nails within 12 mm of ends or within 6 mm of edges are regarded as not effective. As the nail rows in these plates are 32 mm apart, all nails are effective in **Knuckle Nailplates** fixed symmetrical over the joint (3 mm tolerance).

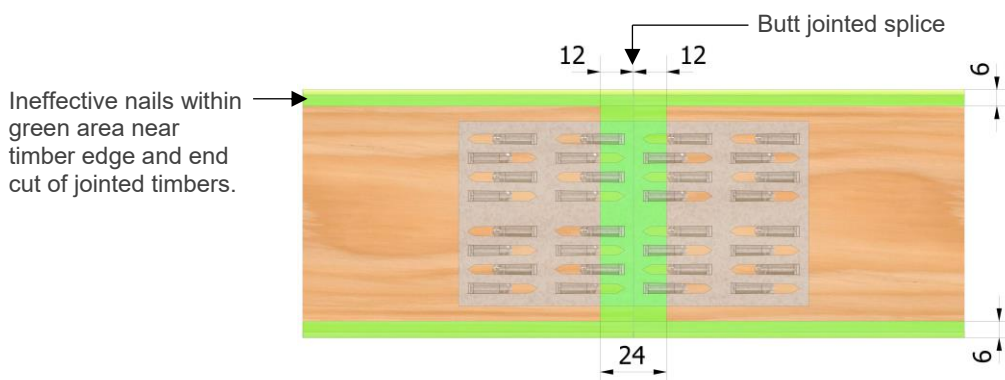

Ineffective Nail Areas in Joints

4. The Design Capacities for Steel Strength includes a capacity reduction factor $\phi = 0.90$
5. Design capacities applies for dry (maximum moisture content of 18%) Radiata Pine and Douglas Fir timber grade SG8 and for timber which meets JD5 timber as defined in AS/NZS 1720.

| Contact details | |
|--|---|
| Manufacture location | Overseas |
| Legal and trading name of manufacturer | Exim Engineering Pty Ltd |
| Legal and trading name of importer | Pryda New Zealand -a Division of ITW New Zealand |
| Importer address for service | 23-29 Poland Road, Wairau Valley, Auckland, 0627, New Zealand |
| Importer website | Pryda.co.nz |
| Importer email | info@prydaanz.com |
| Importer phone number | 0800 88 22 44 |
| Importer NZBN | 9429039833129 |

NZ NAIL-ON DIAGONAL CLEAT

CodeMark >>>
CMNZ-10031

Hammer fixed, easy to use nail-on plates for many support applications.

FEATURES AND BENEFITS

SIMPLE: Can accommodate multiple width timber sizes.

FAST: Fix using Pryda 35 x 3.15mm Timber Connector Nails.

DURABLE: 1mm thick, Z275 steel. Suitable for high load applications such as support cleats when used in pairs.

SPECIFICATIONS

| | |
|-----------------------------|--|
| PRODUCT CODE | NPD |
| STEEL | G300 |
| THICKNESS | 1mm |
| CORROSION RESISTANCE | Z275 |
| FASTENERS REQUIRED | Pryda 35 x 3.15mm Timber Connector Nails |
| HEIGHT | 215mm |
| WIDTH | 90mm (single bracket) |

At the time of print, this product is NOT subject to any known warnings and bans found in Building Act 2004.

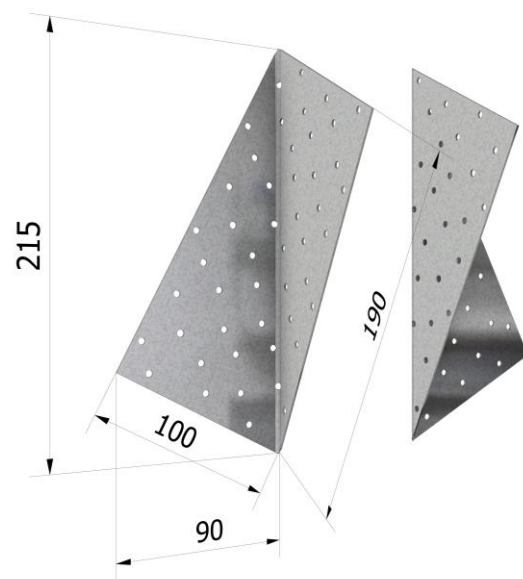

*All dimensions shown in "mm".

NAIL-ON DIAGONAL CLEAT

| PRODUCT CODE | MATERIAL | SIZE | QUANTITY |
|--------------|-------------------------------|------------|-----------------------------|
| NPD | G300 Z275 Galvanised Steel | 90 x 215mm | 10 LH and 10 RH per ctn. |

DURABILITY

The following table provides an easy guide when selecting a Pryda product corrosion protection finish that will meet and exceeds NZS 3604:2011 Table 4.1.

Pryda Nail-On Diagonal cleat is only available in Z275, therefore suitable for “Closed” environment.

| ZONE | LOCATION | ENVIRONMENT | PRODUCT | |
|---------------|--|---|--|--|
| All Zones | Fully enclosed walls, floors, and roof spaces | Closed | Pryda Zinc Coated Products Z275 | |
| Zones B and C | All subfloor fastenings more than 600mm above the ground | Vented 7000mm ² /m ² or LESS | Pryda Stainless Steel 304 Products ⁽³⁾ | |
| | | Vented MORE than 7000mm ² /m ² | Pryda Stainless Steel 304 Products ⁽³⁾ | |
| | All subfloor fastenings within 600mm of the ground | Sheltered and Exposed | | Pryda Stainless Steel 304 Products ⁽³⁾ |
| | | All other structural fixings | Sheltered | |
| Exposed | | | Pryda Stainless Steel 304 Products ⁽³⁾ | |
| Zone D | All structural fixings | Sheltered and Exposed | | Pryda Stainless Steel 304 Products ⁽³⁾ |

Notes:

- 1.All Pryda galvanised products comply with NZS3604:2011 Table 4.2.
- 2.Refer to NZS3604:2011 for all environment definitions.
- 3.Routine inspection and cleaning using soap and fresh warm water is an integral part of the ongoing care and maintenance of stainless steel to preserve its appearance.

STORAGE AND HANDLING

Prior to use, the Pryda products shall be stored in a weatherproof environment and protected from moisture. Care must be taken to avoid any damage to the surface of the product protective galvanised coating and profile that may impact the performance.

COMPLIES WITH THE FOLLOWING PROVISIONS OF THE NEW ZEALAND BUILDING CODE (NZBC)

Clause B1 STRUCTURE: Performance B1.3.1, B1.3.2 and B1.3.4. Loads arising from self-weight, imposed gravity loads arising from use, earthquake, snow, and wind. (i.e., B1.3.3 (a), (b), (f), (g), and (h)). Only some may apply for a specific use of the component.

Clause B2 DURABILITY: Performance B2.3.1 (a) not less than 50 years and B2.3.2.

Clause F2 HAZARDOUS BUILDING MATERIALS: Performance F2.3.1.

APPLICATION AND SCOPE OF USE

Pryda Nail-on Diagonal Cleats are certified when used and installed in accordance with the product datasheet shown connection details. Pryda fasteners approved for the installation form an integral part of the connection and therefore should be used with all Pryda products installation unless otherwise approved by a certified structural Engineer. Only use the product for its intended applications and the selected product material type within the specified environmental condition as outlined in NZS 3604:2011 Table 4.1. (Refer to Durability section for more details).

- Beam to beam
- Joist to beam

NPD DESIGN CAPACITIES AND APPLICATIONS

LOAD DIRECTION 1 (ALWAYS USE AS PAIRS)

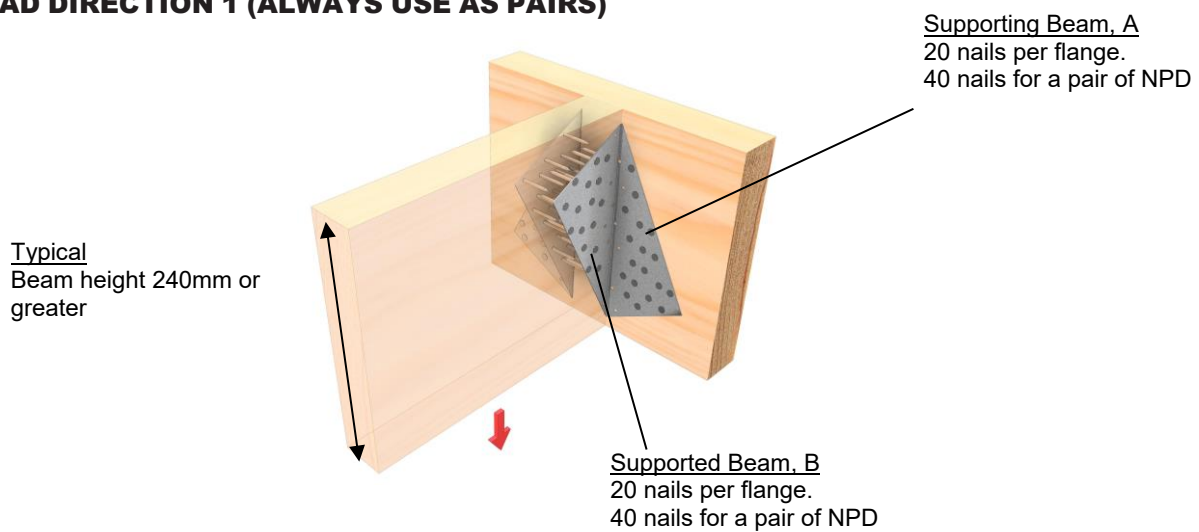

| LOAD CASE | LIMIT STATE DESIGN ϕN_j (kN) FOR A PAIR OF NPD FOR TIMBER JOINT GROUP | |
|-------------------------|---|--|
| | JD5 | |
| 1.35G | 9.3 | |
| 1.2G+1.5Qf | 11.2 | |
| 1.2G+1.5Qr | 12.5 | |
| 1.2G+Wdn or Wind Uplift | 18.5 | |

Notes:

1. Capacities based on having 40 nails to supporting Beam A and 40 nails to supported Beam B. Use Pryda 35 x 3.15mm Timber Connector Nails. Must be used in PAIRS.
2. Use 75 x 3.15mm diameter galvanised flat head nails when nailing into poles. (e.g., girt to pole fixing)
3. Minimum beam thickness shall be equivalent or greater than nail length.
4. Recommended beam height 240mm or greater.
5. Capacities based on vertical and concentric loading.
6. NPD supports variable widths. Width should be limited by the designer to prevent eccentric loading on the bracket.

INSTALLATION FOR BEAM TO BEAM OR TRUSS TO TRUSS CONNECTION

STEP 1



- Position the supported beam to supporting beam, ensuring both beams are vertically plumb, and all edges are aligned.

STEP 2

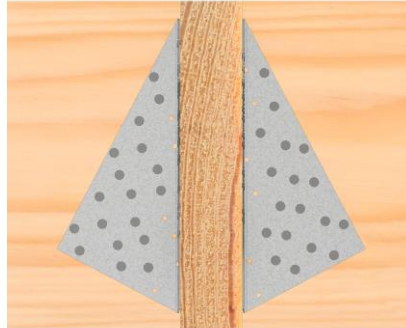

- Position a pair of NPD at right angles on either side of the supported beam. NPD shall be located centrally to beam height. Fix each NPD to each timber member with 20 x Pryda 35 x 3.15mm Timber Connector Nails. 40 nails per bracket.

STEP 3

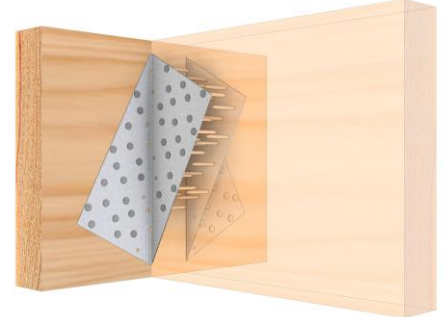

- Repeat the same fixing method to adjacent NPD. Note orientation of each NPD and connection must be installed with a PAIR of NPD.

FASTENING NPD

BUILD WITH CONFIDENCE

Where possible, hand nailing with Pryda Timber Connector nails is always preferred, why?

- Pryda Timber Connector Nails are forged in one piece, unlike clouts that are two pieces soldered together, meaning the head can pop off
- Pryda Nails are the correct diameter, ensuring a tight fit in pre-punched holes = a stronger connection
- Design values and testing have all been conducted using Pryda Timber Connector Nails
- Hand hammered nails ensure correct nail positioning and drive depth (not driven too shallow or too deep)

Machine driven nails are not recommended for fixing NPD

| Contact details | |
|--|---|
| Manufacture location | New Zealand |
| Legal and trading name of manufacturer | Kimberly Tool & Design (NZ) Limited |
| Legal and trading name of supplier | Pryda New Zealand -a Division of ITW New Zealand |
| Supplier address for service | 23-29 Poland Road, Wairau Valley, Auckland, 0627, New Zealand |
| Supplier website | Pryda.co.nz |
| Supplier email | info@prydaanz.com |
| Supplier phone number | 0800 88 22 44 |
| Supplier NZBN | 9429039833129 |

NZ NAIL-ON CLEAT

Universal ties for joining timber at right angles.

CodeMark >>>
CMNZ-10031

FEATURES AND BENEFITS

SIMPLE: Easy to use for right-angle connections.

FAST: Nail fix using on-site hammer.

DURABLE: Made from Stainless Steel Grade 304.

SPECIFICATIONS

| | |
|-----------------------------|-----------------------------------|
| PRODUCT CODE | NPD150/63/S (RH & LH) |
| STEEL | Stainless Steel 304 |
| THICKNESS | 0.9mm |
| CORROSION RESISTANCE | Stainless Steel 304 |
| FASTENER | Pryda 35 x 3.15mm Stainless Steel |
| | Timber Connector Nails |
| PRODUCT DIMENSION | Refer to drawing |

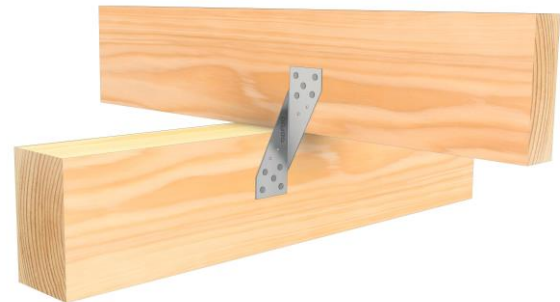

NPD150/63/S LH (LEFT HAND)



NPD150/63/S RH (RIGHT HAND)

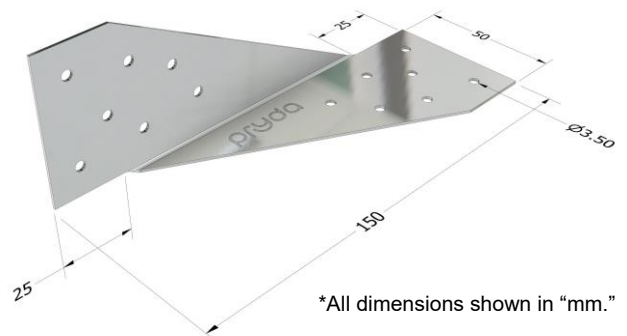

*All dimensions shown in "mm."

At the time of print, this product is NOT subject to any known warnings and bans found in Building Act 2004.

NAIL-ON CLEAT

| PRODUCT CODE | MATERIAL | LENGTH (mm) | WIDTH (mm) |
|--------------|---------------------|-------------|------------|
| NPD150/63/S | Stainless Steel 304 | 150 | 50 |

DURABILITY

The following table provides an easy guide when selecting a Pryda product corrosion protection finish that will meet and exceeds NZS 3604:2011 Table 4.1.

Pryda Nail-On Cleat is only available in Stainless Steel 304, therefore suitable for all environments.

| ZONE | LOCATION | ENVIRONMENT | PRODUCT | |
|---------------|--|--|---|---|
| All Zones | Fully enclosed walls, floors, and roof spaces | Closed | Pryda Zinc Coated Products Z275 | |
| Zones B and C | All subfloor fastenings more than 600mm above the ground | Vented 7000mm ² /m ² or LESS | Pryda Stainless Steel 304 Products ⁽³⁾ | |
| | | Vented MORE than 7000mm ² /m ² | Pryda Stainless Steel 304 Products ⁽³⁾ | |
| | All subfloor fastenings within 600mm of the ground | Sheltered and Exposed | | Pryda Stainless Steel 304 Products ⁽³⁾ |
| | | All other structural fixings | Sheltered | Pryda Stainless Steel 304 Products ⁽³⁾ |
| | Exposed | | Pryda Stainless Steel 304 Products ⁽³⁾ | |
| Zone D | All structural fixings | Sheltered and Exposed | Pryda Stainless Steel 304 Products ⁽³⁾ | |

Notes:

- 1.All Pryda galvanised products comply with NZS3604:2011 Table 4.2.
- 2.Refer to NZS3604:2011 for all environment definitions.
- 3.Routine inspection and cleaning using soap and fresh warm water is an integral part of the ongoing care and maintenance of stainless steel to preserve its appearance.

STORAGE AND HANDLING

Prior to use, the Pryda products shall be stored in a weatherproof environment and protected from moisture. Care must be taken to avoid any damage to the surface of the product protective galvanised coating and profile that may impact the performance.

COMPLIES WITH THE FOLLOWING PROVISIONS OF THE NEW ZEALAND BUILDING CODE (NZBC)

Clause B1 STRUCTURE: Performance B1.3.1, B1.3.2 and B1.3.4. Loads arising from self-weight, imposed gravity loads arising from use, earthquake, snow, and wind. (i.e., B1.3.3 (a), (b), (f), (g), and (h)). Only some may apply for a specific use of the component.

Clause B2 DURABILITY: Performance B2.3.1 (a) not less than 50 years and B2.3.2.

Clause F2 HAZARDOUS BUILDING MATERIALS: Performance F2.3.1.

APPLICATION AND SCOPE OF USE

Pryda Nail-on Cleats (NPD150/63/S) are certified when used and installed in accordance with the product datasheet shown connection details. Pryda fasteners approved for the installation form an integral part of the connection and therefore should be used with all Pryda products installation unless otherwise approved by a certified structural Engineer. Only use the product for its intended applications and the selected product material type within the specified environmental condition as outlined in NZS 3604:2011 Table 4.1. (Refer to Durability section for more details).

DESIGN CAPACITIES

LOAD DIRECTION 1

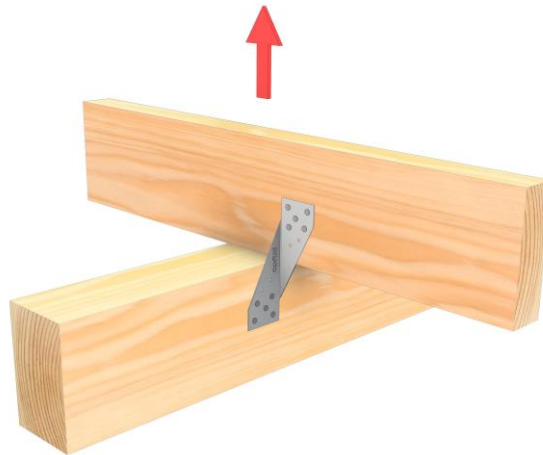

LOAD DIRECTION 1

| LOAD CASE | DESIGN CAPACITY Φ_{NJ} (kN) FOR A SINGLE NPD150/63/S FOR TIMBER JOINT GROUP |
|-----------------------------|--|
| | JD5 |
| 1.2G + Wd or Wind Uplift | 5.5 |

Notes:

1. Fixing details are 5 @ 35 x3.15mm Stainless Steel Pryda Timber Connector Nails into each end. Total 10 nails per bracket.
2. Joist is to be fixed to bearer using 2 x 90 x 3.15mm skew nails. (Not supplied and not shown in connection detail shown)
3. Design capacities applies for dry (maximum moisture content of 18%) Radiata Pine and Douglas Fir timber grade SG8 and for timber which meets JD5 timber as defined in AS/NZS 1720.

NPD150/63/S INSTALLATION

Locating NPD150/63/S

- Joist and Bearer are perpendicular to each other.
- Both joist and bearer are vertically plumb and levelled.
- Locate NPD150/63/S vertically central to junction.
- Select nail holes 20mm away from timber edge for both joist and bearer.
- When installed in PAIRS to resist horizontal loads, locate NPD150/63/S across from each other on opposing faces.
- NPD150/63/S installed vertically.
- Minimum timber thickness 35mm.

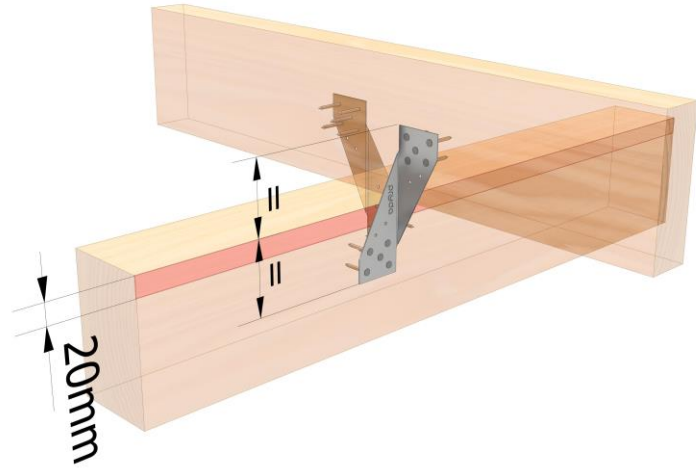

INSTALLATION FOR SINGLE NPD150/63/S TO JOIST CROSSING PERPENDICULAR TO BEAM CONNECTION

STEP 1



- Position the NPD150/63/S ensuring it is plumb and fix 5 x Pryda 35 x 3.15mm Stainless Steel Timber Connector Nails into the supporting timber member.
- Ensure the NPD150/63/S is vertical and firmly against the face of supporting and supported member.

STEP 2



- Position the upper timber member and fix another 5 x Pryda 35 x 3.15mm Stainless Steel Timber Connector Nails.

| Contact details | |
|--|---|
| Manufacture location | New Zealand |
| Legal and trading name of manufacturer | Kimberly Tool & Design (NZ) Limited |
| Legal and trading name of supplier | Pryda New Zealand -a Division of ITW New Zealand |
| Supplier address for service | 23-29 Poland Road, Wairau Valley, Auckland, 0627, New Zealand |
| Supplier website | Pryda.co.nz |
| Supplier email | info@prydaanz.com |
| Supplier phone number | 0800 88 22 44 |
| Supplier NZBN | 9429039833129 |

NZ NAIL-ON PLATES AND ANGLE

A pre-punched plates for joining or connecting timber.

CodeMark 
CMNZ-10031

FEATURES AND BENEFITS

SIMPLE: Pre-punch holes ready for onsite application using nail fix or screw fix.

FAST: Simply select the correct plate size and type, place into position, and fasten through the pre-punched holes to suit design application.

DURABLE: Any heavy-duty timber connection where a **Knuckle nail plate** will not suffice. Joining beams. Repair work over existing fixings.

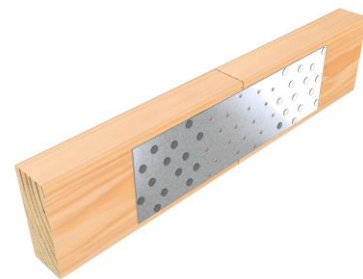

SPECIFICATIONS

| | |
|-----------------------------|--|
| PRODUCT CODE | NPA ⁽¹⁾ , NPB ⁽²⁾ |
| STEEL | G300 or Stainless Steel 304 ⁽³⁾ |
| THICKNESS | 1mm for Z275 |
| | 0.9mm for Stainless Steel 304 ⁽³⁾ |
| CORROSION RESISTANCE | Z275 or Stainless Steel 304 ⁽³⁾ |
| PRODUCT DIMENSION | Sizes shown in Design Capacities table |

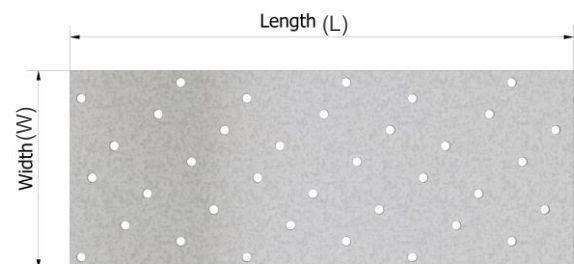

NPA(W)/(L), NPB(W)/(L)

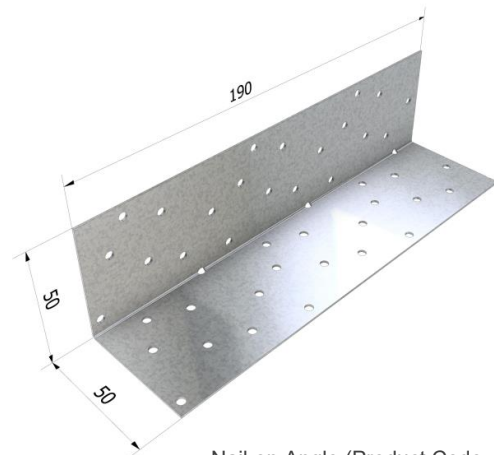

Nail-on Angle (Product Code: NPA)

Notes:

- 1) Refer to table for available sizes and style. Flat plate style or 90 degrees angle style.
- 2) NPB is made from 2mm thick steel. Refer to table for available sizes and style.
- 3) NPA100/190SS is the only Nail-On plate manufactured from stainless steel 316.

At the time of print, this product is NOT subject to any known warnings and bans found in Building Act 2004.

*All dimensions shown in "mm".

Pryda Nail-on Plates are flat, galvanised, or stainless-steel plates which are nail-fixed to timber to form several types of joints. Their medium to high load capacities and wide range of sizes makes them ideally suited for on-site work.

Product codes below are made up from: Width/Length.

| PRODUCT CODE | MATERIAL | PLATE STYLE | STEEL THICKNESS | WIDTH (mm) | LENGTH (mm) |
|--------------------|-----------------------------|---------------------|-----------------|------------|-------------|
| NPA75/125 | G300, Z275 Galvanised Steel | Flat | 1 | 75 | 125 |
| NPA75/190 | | Flat | 1 | 75 | 190 |
| NPA75/250 | | Flat | 1 | 75 | 250 |
| NPA75/315 | | Flat | 1 | 75 | 315 |
| NPA75/380 | | Flat | 1 | 75 | 380 |
| NPA100/190 | | Flat | 1 | 100 | 190 |
| NPA100/315 | | Flat | 1 | 100 | 315 |
| NPA150/315 | | Flat | 1 | 150 | 315 |
| NPA ⁽¹⁾ | | Angle | 1 | 100 | 190 |
| NPB75/380 | | Flat | 2 | 75 | 380 |
| NPB75 BAR * | | Flat | 2 | 75 | 1260 |
| NPB100 BAR | | Flat | 2 | 100 | 1260 |
| NPB150 BAR* | | Flat | 2 | 150 | 1260 |
| NPA75BAR/S* | | Stainless Steel 304 | Flat | 1 | 75 |
| NPA100BAR/S | Flat | | 1 | 100 | 1260 |
| NPA150BAR/S* | Flat | | 1 | 150 | 1260 |
| NPA100/190SS | Stainless Steel 316 | Flat | 1 | 100 | 190 |

Notes:

1. NPA Nail-on Angle is NPA100/190 folded 90° along its length.
2. The product marked with * is no longer available.



Narrow timber joining.



Wide timber joining.

DURABILITY

The following table provides an easy guide when selecting a Pryda product corrosion protection finish that will meet and exceeds NZS 3604:2011 table 4.1.

| ZONE | LOCATION | | ENVIRONMENT | PRODUCT |
|---------------|--|--|-------------|---|
| All Zones | Fully enclosed walls, floors, and roof spaces | | Closed | Pryda Zinc Coated Products Z275 |
| Zones B and C | All subfloor fastenings more than 600mm above the ground | Vented 7000mm ² /m ² or LESS | Sheltered | Pryda Stainless Steel 304 Products ⁽³⁾ |
| | | Vented MORE than 7000mm ² /m ² | Exposed | Pryda Stainless Steel 304 Products ⁽³⁾ |
| | All subfloor fastenings within 600mm of the ground | Sheltered and Exposed | | Pryda Stainless Steel 304 Products ⁽³⁾ |
| | All other structural fixings | Sheltered | | Pryda Stainless Steel 304 Products ⁽³⁾ |
| Exposed | | Pryda Stainless Steel 304 Products ⁽³⁾ | | |
| Zone D | All structural fixings | Sheltered and Exposed | | Pryda Stainless Steel 304 Products ⁽³⁾ |

Notes:

- 1.All Pryda galvanised products comply with NZS3604:2011 Table 4.2.
- 2.Refer to NZS3604:2011 for all environment definitions.
- 3.Routine inspection and cleaning using soap and fresh warm water is an integral part of the ongoing care and maintenance of stainless steel to preserve its appearance.

STORAGE AND HANDLING

Prior to use, the Pryda products shall be stored in a weatherproof environment and protected from moisture. Care must be taken to avoid any damage to the surface of the product protective galvanised coating and profile that may impact the performance.

COMPLIES WITH THE FOLLOWING PROVISIONS OF THE NEW ZEALAND BUILDING CODE (NZBC)

Clause B1 STRUCTURE: Performance B1.3.1, B1.3.2 and B1.3.4. Loads arising from self-weight, imposed gravity loads arising from use, earthquake, snow, and wind. (i.e., B1.3.3 (a), (b), (f), (g), and (h)). Only some may apply for a specific use of the component.

Clause B2 DURABILITY: Performance B2.3.1 (a) not less than 50 years and B2.3.2.

Clause F2 HAZARDOUS BUILDING MATERIALS: Performance F2.3.1.

INSTALLATION NAIL-ON PLATE

Use only Pryda 35 x 3.15mm galvanised Timber Connector Nails or equivalent nails with these connectors. Stainless steel nails must be used with stainless steel Nail-on plates.

Number of Nail Holes per Plate

| PLATE WIDTH | PLATE LENGTH | | | | |
|-------------|--------------|-----|-----|-----|-----|
| | 125 | 190 | 250 | 315 | 380 |
| 75 | 23 | 36 | 47 | 59 | 71 |
| 100 | 31 | 48 | 63 | 79 | 95 |
| 150 | 47 | 71 | 94 | 118 | 143 |

Note:

1. Nail density is **approx.** one nail per 400 mm²
2. Nails must be driven into all holes (i.e., all holes filled), except for holes within 63 mm of timber ends and 16 mm of timber edges, to achieve the full Design Capacities.

Design Capacities for a Tension Joint

Limit State Design capacities for **Pryda Nail-on Plates** per pair of plates are as tabulated below with conditions:

- All nail holes filled except within 63mm of timber ends.
- Minimum edge distance to nail center = 5D = 16mm.
- Minimum edge distance plate to timber edge = 5mm.
- Loading case = 1.2G+1.5Qr (Dead Load+ Roof Live).
- Nails within 63mm of butt joint are neglected.
- Positioning tolerance along plate length = 3 mm.

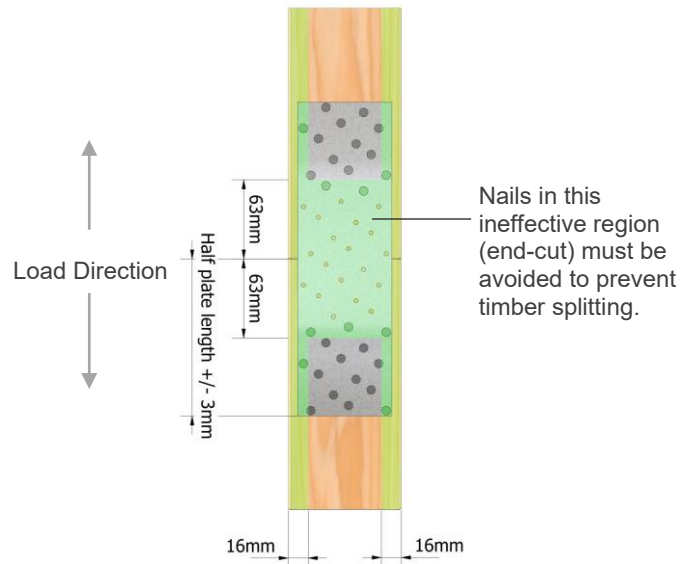

TABLE 1: TENSION LOAD PARALLEL TO GRAIN

| PRODUCT CODE | TIMBER WIDTH (mm) | STEEL THICKNESS (mm) | WIDTH (mm) | LENGTH (mm) | DESIGN CAPACITIES (ΦNJ) IN kN FOR PAIR OF NPA PLATES (TENSION LOAD PARALLEL TO GRAIN ONLY) | | | |
|--------------|-------------------|----------------------|------------|-------------|--|--------------|--------------|--------------------------|
| | | | | | 1.35G | 1.2G + 1.5Qf | 1.2G + 1.5Qr | 1.2G + Wd or Wind uplift |
| NPA75/125 | 90 | 1 | 75 | 125 | N/S | N/S | N/S | N/S |
| NPA75/190 | 90 | 1 | 75 | 190 | 3.5 | 5 | 4.5 | 7 |
| NPA75/250 | 90 | 1 | 75 | 250 | 5.5 | 8 | 7 | 11.5 |
| NPA75/315 | 90 | 1 | 75 | 315 | 10 | 14 | 12.5 | 20.5 |
| NPA75/380 | 90 | 1 | 75 | 380 | 14.5 | 20 | 18 | 29.5 |
| NPA100/190 | 120 | 1 | 100 | 190 | 5 | 7 | 6 | 10 |
| NPA100/315 | 120 | 1 | 100 | 315 | 19 | 23 | 26 | 38 |
| NPA150/315 | 170 | 1 | 150 | 315 | 23.5 | 32 | 28.5 | 47.5 |
| NPB75/380 | 90 | 2 | 75 | 380 | 14.5 | 20 | 18 | 29.5 |

NOTES:

- Design capacities applies for dry (maximum moisture content of 18%) Radiata Pine and Douglas Fir timber grade SG8 and for timber which meets JD5 timber as defined in AS/NZS 1720.
- The nail capacities (ΦNj) given in the table above can resist a resultant design force arising from an axial tension load.
- The design capacities tabulated above apply directly to joints on JD5 (SG8) timber using k1 = 0.8. The resultant capacity must not exceed the maximum Tension load given.
- Pryda TCS12-35 screws may be substituted for Pryda Timber Connector nails. To achieve equivalent capacity, use 2 screws for every 4 nails (in JD5). The end/edge distance and spacing requirements for screws are different to nails and therefore should be specified by the designer.
- All NPA and NPB Bar shall be trimmed to the set size found in Table 1 and adopt the same capacities and conditions of use.
- Use galvanised nails with galvanised plates and stainless steel nails with stainless steel plates.
- 'N/S' in the above table signifies that the plate is not suitable for a butt-joint connection, due to ineffectiveness of nails resulting from end-distance violations.

NAIL-ON ANGLE

Ideal for beam to bearer situations to give a strong, economic alternative to framing brackets where the width of the beam is non-standard.

INSTALLATION NAIL-ON ANGLE

- Always used in PAIRS on opposing faces.
- Use Pryda 35 x 3.15mm Timber Connector Nails or equivalent.
- Use 75 x 3.15 diameter Flat Head nails when nailing into poles.
- Use Pryda Timber Connector Screw TCS12-35 with single laminate, 35mm minimum width timber.

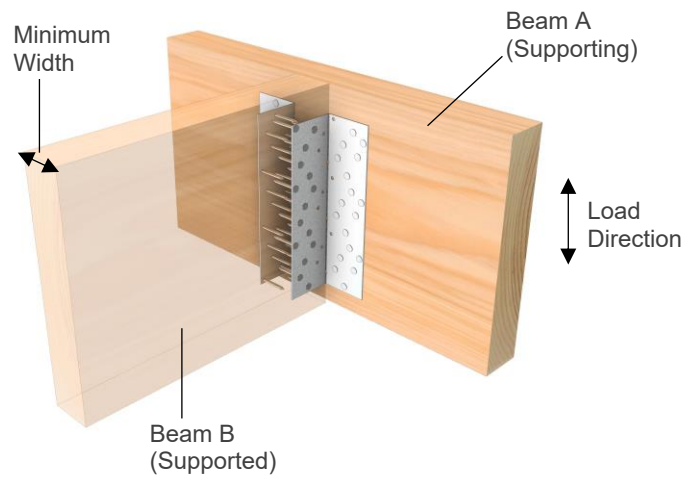
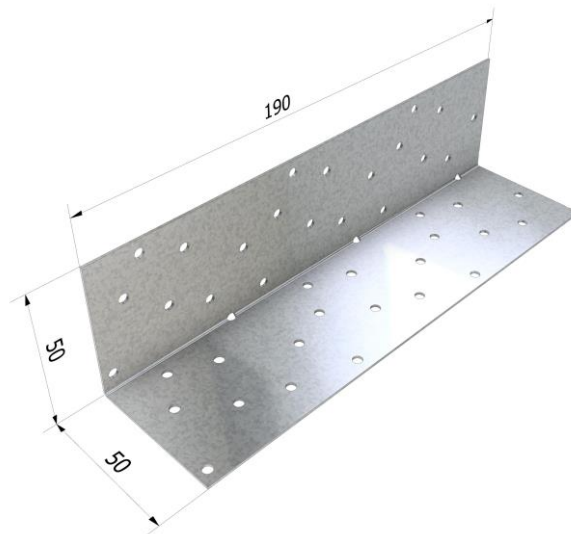

Variable width connection utilising nails. Suitable for a high truss uplift and gravity loads. All nail holes to be filled.

Nail Fixing – Pryda 35 x 3.15mm Timber Connector nails

| LOAD CASE | DESIGN CAPACITIES (ΦN _J) IN kN |
|--------------|--|
| | OPTION 1 |
| | ALL NAIL HOLES TO BE FILLED TO BEAM A AND BEAM B EACH FLANGE |
| | JD5 |
| 1.2G + 1.5Qr | 31.1 |
| Wind Uplift | 46 |

Notes:

1. Beam A = Supporting member, Beam B = Supported member.
2. Design capacities applies for dry (maximum moisture content of 18%) Radiata Pine and Douglas Fir timber grade SG8 and for timber which meets JD5 timber as defined in AS/NZS 1720.
3. The down capacities provided above are for 1.2G+1.5Qr (Dead+Roof Live Load). All capacities are limit state design values and not characteristic strength therefore these may be compared directly to Pryda design software output.

APPLICATION AND SCOPE OF USE

Pryda Nail-On Plate and Nail-on Angle are certified when used and installed in accordance with the product datasheet shown connection details. Pryda fasteners approved for the installation form an integral part of the connection and therefore should be used with all Pryda products installation unless otherwise approved by a certified structural Engineer. Only use the product for its intended applications and the selected product material type within the specified environmental condition as outlined in NZS 3604:2011 Table 4.1. (Refer to Durability section for more details). Fastener material type shall match the selected Pryda product. i.e., Galvanised fasteners with galvanised products. Stainless Steel fasteners with stainless steel products.

- Joining timber under tension loads (Flat Plate only)
- Truss Support (NPA – Angle)
- Rectification work
- Tie-down anchor

| Contact details | |
|--|---|
| Manufacture location | New Zealand |
| Legal and trading name of manufacturer | Kimberly Tool & Design (NZ) Limited |
| Legal and trading name of supplier | Pryda New Zealand -a Division of ITW New Zealand |
| Supplier address for service | 23-29 Poland Road, Wairau Valley, Auckland, 0627, New Zealand |
| Supplier website | Pryda.co.nz |
| Supplier email | info@prydaanz.com |
| Supplier phone number | 0800 88 22 44 |
| Supplier NZBN | 9429039833129 |

NZ STRAP NAIL

Hammer fixed and easy to use connector for multiple applications.

CodeMark 
CMNZ-10031

FEATURES AND BENEFITS

SIMPLE: Can be installed without any special gear or nails, only a hammer is required for install

FAST: Hammer the pre-punched Claw nails and you are done. Timesaving and therefore, cost-saving

DURABLE: Twisted form of the Claw nails are suitable for all types of un-treated timber ranging from the lightest softwoods to the densest hardwoods. Made from 1mm G300 Z275 steel.



SPECIFICATIONS

| | |
|-----------------------------|---|
| PRODUCT CODE | SN25 ⁽¹⁾ , MPSN50^(*) , MPSN5 ⁽²⁾ , SN50L ⁽³⁾ , SN50 ⁽²⁾ |
| STEEL | G300 |
| THICKNESS | 1mm |
| CORROSION RESISTANCE | Z275 |
| FASTENERS REQUIRED | Pre-punched nails |
| LENGTH | 100mm ⁽¹⁾ , 100mm ⁽²⁾ , 150mm ⁽³⁾ |
| WIDTH | 25mm ⁽¹⁾ , 50mm ⁽²⁾ , 50mm ⁽³⁾ |
| QUANTITY | *Refer to next table |

At the time of print, this product is NOT subject to any known warnings and bans found in Building Act 2004.

NOTE: The product marked with * is no longer available.

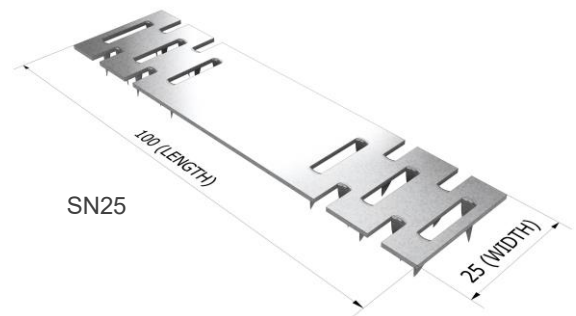

SN25

MPSN50*,
SN50,
MPSN5

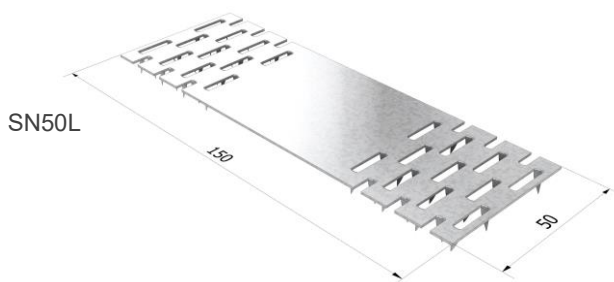

SN50L

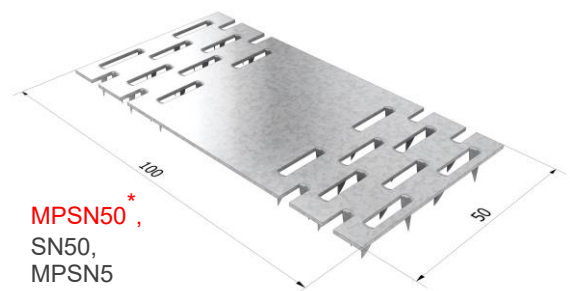

*All dimensions shown are in "mm".

DURABILITY

The following table provides an easy guide when selecting a Pryda product corrosion protection finish that will meet and exceeds NZS 3604:2011 table 4.1.

Pryda Strap Nails are only available in Z275, therefore suitable for “Closed” environment.

| ZONE | LOCATION | | ENVIRONMENT | PRODUCT |
|---------------|--|--|-------------|---|
| All Zones | Fully enclosed walls, floors, and roof spaces | | Closed | Pryda Zinc Coated Products Z275 |
| Zones B and C | All subfloor fastenings more than 600mm above the ground | Vented 7000mm ² /m ² or LESS | Sheltered | Pryda Stainless Steel 304 Products ⁽³⁾ |
| | | Vented MORE than 7000mm ² /m ² | Exposed | Pryda Stainless Steel 304 Products ⁽³⁾ |
| | All subfloor fastenings within 600mm of the ground | Sheltered and Exposed | | Pryda Stainless Steel 304 Products ⁽³⁾ |
| | All other structural fixings | Sheltered | | Pryda Stainless Steel 304 Products ⁽³⁾ |
| Exposed | | Pryda Stainless Steel 304 Products ⁽³⁾ | | |
| Zone D | All structural fixings | Sheltered and Exposed | | Pryda Stainless Steel 304 Products ⁽³⁾ |

Notes:

1.All Pryda galvanised products comply with NZS3604:2011 Table 4.2.

2.Refer to NZS3604:2011 for all environment definitions.

3.Routine inspection and cleaning using soap and fresh warm water is an integral part of the ongoing care and maintenance of stainless steel to preserve its appearance.

STORAGE AND HANDLING

Prior to use, the Pryda products shall be stored in a weatherproof environment and protected from moisture. Care must be taken to avoid any damage to the surface of the product protective galvanised coating and profile that may impact the performance.

COMPLIES WITH THE FOLLOWING PROVISIONS OF THE NEW ZEALAND BUILDING CODE (NZBC)

Clause B1 STRUCTURE: Performance B1.3.1, B1.3.2 and B1.3.4. Loads arising from self-weight, imposed gravity loads arising from use, earthquake, snow, and wind. (i.e., B1.3.3 (a), (b), (f), (g), and (h)). Only some may apply for a specific use of the component.

Clause B2 DURABILITY: Performance B2.3.1 (a) not less than 50 years and B2.3.2.

Clause F2 HAZARDOUS BUILDING MATERIALS: Performance F2.3.1.

STRAP NAIL

| PRODUCT CODE | MATERIAL | WIDTH (mm) | LENGTH (mm) |
|--------------|-------------------------------------|------------|-------------|
| SN25 | 1.0mm G300 Z275 Galvanised Steel | 25 | 100 |
| MPSN50* | | 50 | 100 |
| MPSN5 | | 50 | 100 |
| SN50 | | 50 | 100 |
| SN50L | | 50 | 150 |

NOTE: The product marked with * is no longer available.

STRAP NAIL CAPACITY – LOADING ALONG THE PLATE EXAMPLES.

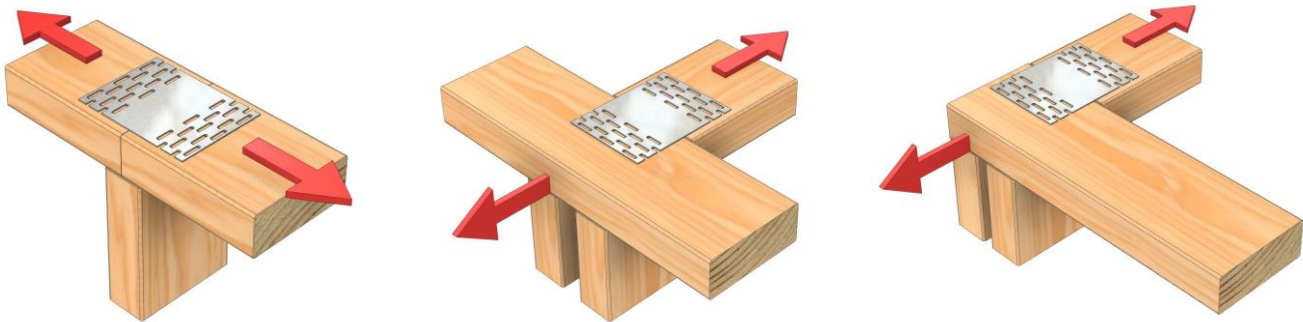

| PRODUCT CODE | WIDTH (mm) | TEETH EACH END | DESIGN CAPACITY fNJ PER STRAP NAIL (kN) FOR TIMBER JOINT GROUP: |
|----------------------------|------------|----------------|---|
| | | | JD5 |
| MPSN2 | 25 | 10 | 1.5 |
| MPSN50*, MPSN5, SN50 | 50 | 16 | 3 |
| SN50L | 50 | 16 | 4.1 |

Notes:

1. Design capacities applies for dry (maximum moisture content of 18%) Radiata Pine and Douglas Fir timber grade SG8 and for timber which meets JD5 timber as defined in AS/NZS 1720.
2. The above capacities are given for the wind load case. For other load cases, decrease capacities by multiplying with the corresponding factor tabulated below:
3. Complies with NZS3604 Section 8 Walls for metal plate joints Up to 3 kN for MPSN5, SN50, and SN50L as referenced in Figure 8.15 and Figure 8.16.
4. The product marked with * is no longer available.

APPLICATION AND SCOPE OF USE

Pryda Strap Nails are certified when used and installed in accordance with the product datasheet shown connection details. Pryda fasteners approved for the installation form an integral part of the connection and therefore should be used with all Pryda products installation unless otherwise approved by a certified structural Engineer. Only use the product for its intended applications and the selected product material type within the specified environmental condition as outlined in NZS 3604:2011 Table 4.1. (Refer to Durability section for more details).

- Connecting top plates to external walls at right angles.
- Connecting top plates.

INSTALLATION

Pryda Strap Nail, a pre-punched nail plate which offers a quick, simple, economical, and easy to use method of jointing timber plates normally jointed by more time-consuming methods. Pryda Strap Nail uses the sharper tooth profile featuring the exclusive pre-punched twisted nail. This results in increased holding power due to better penetration of all timber types.

Installation is just a matter of hammering in the plate, however before doing so, make sure the Strap Nail is:

- Positioned centrally over the joint line with equal lengths of the plate on either side.
- Positioned centrally to the edges of the timber.
- Positioned parallel with the edge of the timber.
- Timber joining edge is free from timber defects such as knots, waness, checks, shakes, and splits.
- Gaps between joints shall not be greater than 3mm.

| Contact details | |
|--|---|
| Manufacture location | New Zealand |
| Legal and trading name of manufacturer | Fairfit Engineering |
| Legal and trading name of supplier | Pryda New Zealand -a Division of ITW New Zealand |
| Supplier address for service | 23-29 Poland Road, Wairau Valley, Auckland, 0627, New Zealand |
| Supplier website | Pryda.co.nz |
| Supplier email | info@prydaanz.com |
| Supplier phone number | 0800 88 22 44 |
| Supplier NZBN | 9429039833129 |

www.pryda.co.nz

FOR MORE INFORMATION CALL 0800 88 22 44 OR EMAIL INFO@PRYDA.CO.NZ